

**SOLAR SPOT**YOUR ONLINE SOLAR SUPPLY STORE
a Division of 5D Innovations cc

Cape Town | Pretoria | RSA Nationwide



C: +27 78 012 9105

T: +27 12 942 5773

sales@solarspot.co.za



technical@solarspot.co.za

www.solarspot.co.za**6FM200A-X****12V 200Ah(10hr)**

Overview

The rechargeable batteries are lead-lead dioxide systems. The dilute sulfuric acid electrolyte is absorbed by separators and plates and thus immobilized. Should the battery be accidentally overcharged producing hydrogen and oxygen, special oneway valves allow the gases to escape thus avoiding excessive pressure build-up. Otherwise, the battery is completely sealed and is, therefore, maintenance-free, leak proof and usable in any position.



Battery Construction

| | | | | | | | | |
|--------------|----------------|----------------|-----------|-------|--------------|----------|------------|---------------|
| Component | Positive plate | Negative plate | Container | Cover | Safety valve | Terminal | Separator | Electrolyte |
| Raw material | Lead dioxide | Lead | ABS | ABS | Rubber | Copper | Fiberglass | Sulfuric acid |

General Features

- Positive and negative plates in lead-calcium-tin alloy;
- Stable Quality&High Reliability;
- Sealed Construction;
- Long Service Life;
- Maintenance-Free Operation;
- Low Pressure Venting System;
- Low Self Discharge;
- U.L.Component Recognition;
- Six months shelf life at 20°C;
- Design life 10 years

Battery Specification

| Performance Characteristics | |
|--|--------------|
| Nominal Voltage | 12V |
| Number of cell | 6 |
| Design Life | 10 years |
| Nominal Capacity 77°F(25°C) | |
| 10 hour rate (20.0A, 10.8V) | 200Ah |
| 5 hour rate (36.0A, 10.5V) | 180Ah |
| 1 hour rate (128A, 9.6V) | 128Ah |
| Internal Resistance | |
| Fully Charged battery 77°F(25°C) | ≤4.0 mOhms |
| Self-Discharge | |
| 3% of capacity declined per month at 20°C(average) | |
| Operating Temperature Range | |
| Discharge | -20-60°C |
| Charge | -10-60°C |
| Storage | -20-60°C |
| Max. Discharge Current 77°F(25°C) | 1000A(5s) |
| Short Circuit Current | 3300A |
| Charge Methods: Constant Voltage Charge 77°F(25°C) | |
| Cycle use | 2.40-2.45VPC |
| Maximum charging current | 60.0A |
| Temperature compensation | -30mV/°C |
| Standby use | 2.20-2.30VPC |
| Temperature compensation | -20mV/°C |

Dimensions and Weight

| | |
|--------------------------|------------|
| Length(mm / inch) | 522 / 20.6 |
| Width(mm / inch) | 238 / 9.37 |
| Height(mm / inch) | 218 / 8.58 |
| Total Height(mm / inch) | 223 / 8.78 |
| Approx. Weight(Kg / lbs) | 65.0 / 143 |

* Weight deviation: ± 5%

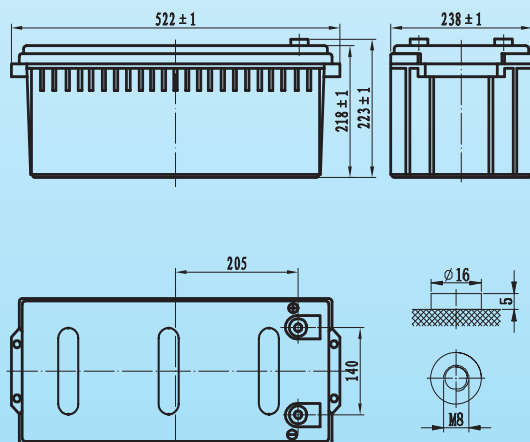

Discharge Constant Current (Amperes at 77°F25°C)

| End Point | | | | | | | | |
|------------|-------|-------|-------|-------|-----|------|------|------|
| Volts/Cell | 10min | 15min | 30min | 45min | 1h | 3h | 5h | 10h |
| 1.60V | -- | 360 | 220 | 159 | 128 | 57.6 | 38.2 | 20.4 |
| 1.65V | -- | 350 | 212 | 153 | 124 | 55.6 | 37.2 | 20.3 |
| 1.70V | -- | 337 | 206 | 149 | 120 | 55.0 | 36.6 | 20.2 |
| 1.75V | -- | 319 | 200 | 145 | 117 | 53.4 | 36.0 | 20.1 |
| 1.80V | -- | 269 | 187 | 140 | 114 | 51.0 | 35.4 | 20.0 |

Discharge Constant Power (Watts at 77°F25°C)

| End Point | | | | | | | | |
|------------|-------|-------|-------|-------|-----|------|------|------|
| Volts/Cell | 10min | 15min | 30min | 45min | 1h | 3h | 5h | 10h |
| 1.60V | -- | 625 | 402 | 294 | 230 | 109 | 73.0 | 40.2 |
| 1.65V | -- | 604 | 390 | 286 | 225 | 107 | 72.0 | 39.2 |
| 1.70V | -- | 586 | 382 | 279 | 221 | 105 | 71.2 | 38.4 |
| 1.75V | -- | 578 | 372 | 274 | 217 | 101 | 70.2 | 37.6 |
| 1.80V | -- | 554 | 364 | 270 | 215 | 98.0 | 69.3 | 36.7 |

(Note)The above characteristics data are average values obtained within three charge/discharge cycles not the minimum values.All data shall be changed without notice, Vision reserves the right to explain and update the information contained hereinto.



VISION GROUP
Shenzhen Center Power
Tech.Co.Ltd.,

6FM200A-X

12V 200Ah(10hr)

