



SOLAR SPOT

YOUR ONLINE SOLAR SUPPLY STORE
a Division of 5D Innovations cc

Cape Town | Pretoria | RSA Nationwide



C: +27 78 012 9105

T: +27 12 942 5773

sales@solarspot.co.za



technical@solarspot.co.za

www.solarspot.co.za

REVOV BATTERY PACK

Assembly and Installation Guide



FREEDOM
FROM DEPENDENCE

WWW.REVOV.CO.ZA

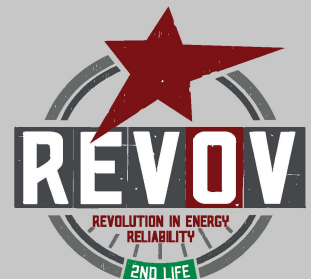

CONTENTS

Preparation

Step 1	Get Ready - Parts, Cabling and Tools	02
--------	--------------------------------------	----

Assembling and Installing the Revov Battery Pack

Step 2	Battery Placement	05
Step 3	Connect the Batteries in series with the BLACK interconnect cable	06
Step 4	Connect the main -ve out from the Batteries to the BMS	07
Step 5	Connect Monitoring Cables	08
Step 6	Main Power Cables out of cabinet from BMS and from Batteries	09
Step 7	Powering on the BMS itself	10
	Balance of System (BoS)	12

STEP 1

- Get Ready - Parts, Cables, Tools

STEP 2

- Select and place Cabinet in suitable location
- Place matched pair of batteries in the cabinet

STEP 3 - BLACK

- Connect Black interconnect cable between Battery 1 -ve and Battery 2 +ve

STEP 4 - BLUE

- Place the BMS in the cabinet
- Connect the Blue Cable from Battery 2 -ve to the BMS -ve terminal

STEP 5 - COMMS

- Connect the Black Comms cables from Battery 1 to BMS
- Connect the Black Comms cables from Battery 2 to BMS

STEP 6 - BROWN BLUE

- Tape the external end of the blue cable and the brown cable with electrical insulation tape
- Connect the brown cable to the +ve on Battery 1 and feed the end out of the cabinet (This will connect through any fuses, buzz bars and breakers to your Inverter +ve terminal)
- Connect the blue cable to the BMS -ve out terminal (This will connect through any fuses, buzz bars and breakers to your Inverter -ve terminal)

STEP 7 - BROWN

- Power up the BMS, Connect the brown BMS power cable to the +ve terminal on battery 2

PREPARATION

Step 1 Get Ready - Parts, Cabling and Tools

Watch the video of this step here:



This Section will run through the parts, cables and tools required to complete the battery pack assembly.

A. YOUR BATTERY PACK SHOULD CONTAIN:

1. 2 matched Batteries they will have the same serial number
2. A cable pack with all the necessary fully labelled cables.
3. A Battery Management System (BMS)
4. A cabinet or frame cabinet to install everything in (optional)

B. PARTS

Your Revov Batteries:

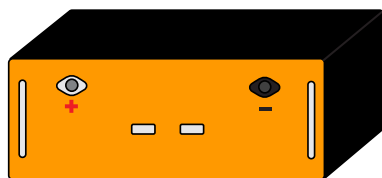

Revov LiFe Battery



Revov 2nd Life Battery

Your Revov BMS:

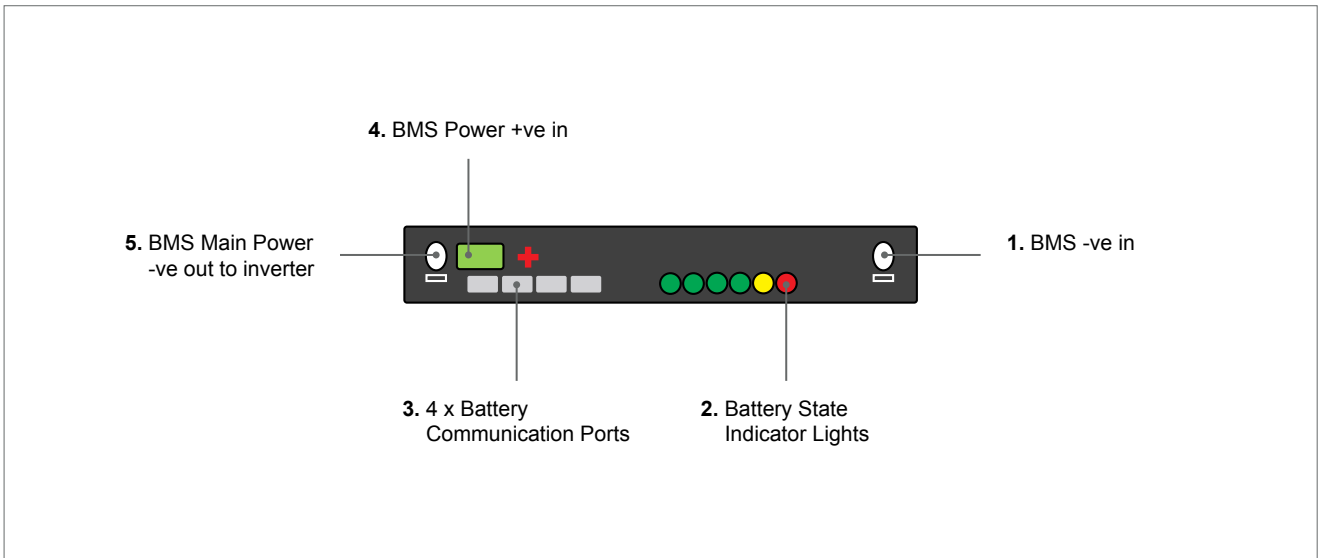

BMS Front Face Features (see labels on BMS Picture):

1. The -ve terminal in from the battery pack
2. Battery State indicator lights
3. Four battery monitoring ports
4. The power for the BMS (small brown cable into this green connector, which draws power from the positive terminal of the battery.)
5. The -ve terminal out to the inverter
 - Negative line BMS – Connect to negative terminal on Battery 2 and then to negative terminal on Inverter
 - Maximum current through the BMS 150-160 Amp
 - The power from the batteries travels through the BMS to allow for power monitoring and management during power output to power your home or business and during re-charging. This power travels in at the -ve terminal on the left of the BMS and out to the BOS from the +ve terminal on the left.
 - The BMS has 4 ports (2 for each battery) that connect to the Batteries and allow for the performance and temperature monitoring of the cells inside the batteries. Basic information from the batteries is then displayed through the diagnostic lights on the BMS. The BMS passes more detailed information to the inverter or any monitoring system you may install.
 - The BMS needs its own power to operate and it gets this power directly from the battery pack itself through its own power cable.

C. CABLES

Your Revov Cable Pack:

- 1x Black Battery Interconnect Cable



- 1x Blue Battery -ve to BMS -ve in Cable



- 4x Black Battery to BMS Comms Cables – These are marked ACB1, ACB2, ACB3 and ACB4



- 1x Brown Battery to Inverter Cable



- 1x Blue BMS to Inverter Cable



- 1x Brown BMS Power Cables

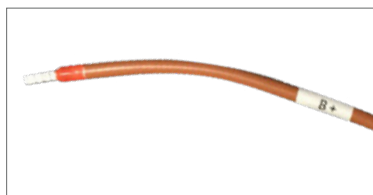

D. TOOLS

What you'll need to complete the installation:

- Size 12 metric spanner or socket wrench (for battery terminal connections)
- Star screw driver (for BMS terminal connections)
- Small straight screwdriver (for the green power connector on the BMS)
- Insulation tape

ASSEMBLY & INSTALLATION

Step 2 Battery Placement

Watch the video of this step here:



1. Put cabinet in the "right place".
 - a. You don't need venting or circulation with Revov LiFe batteries such as was required for many lead-acid battery installations.
2. Put batteries into the cabinet one on top shelf and one on bottom shelf.
3. Plan cable routes
 - a. Inside cabinet
 - b. from cabinet to inverter,
 - c. from inverter to load,
 - d. from inverter to charging source/s
4. All the necessary interfaces to connect are on the front of the battery and the BMS and there are no side flanges or brackets. This makes it easy to install the battery into a cabinet.
5. Having all the interfaces and handles on the front of the battery makes installation and later maintenance and troubleshooting a breeze.

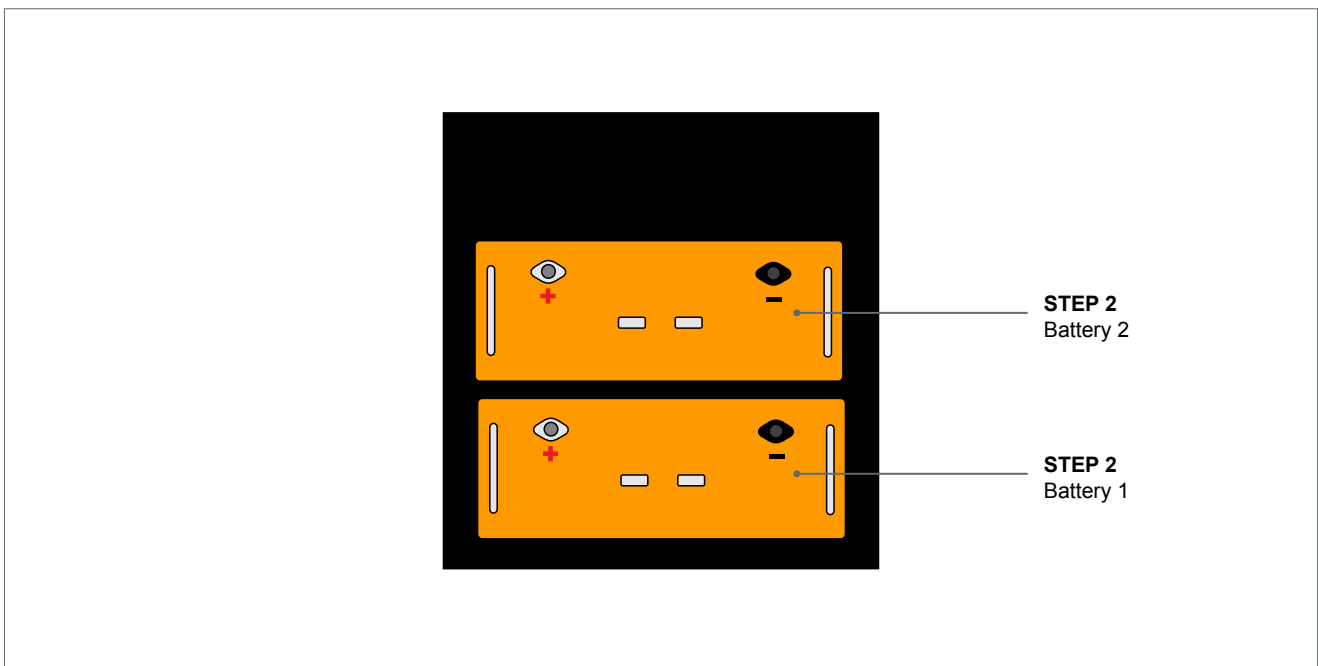

Step 3

 Connect the Batteries in series with the BLACK interconnect cable

Watch the video of this step here:



1. Use the black cable to connect the matched pair of batteries.
2. When facing the battery, connect one end of the black cable to the righthand terminal of the bottom battery. In other words, connect the end of the black cable labelled Batt1 -ve to the negative terminal of Battery 1.

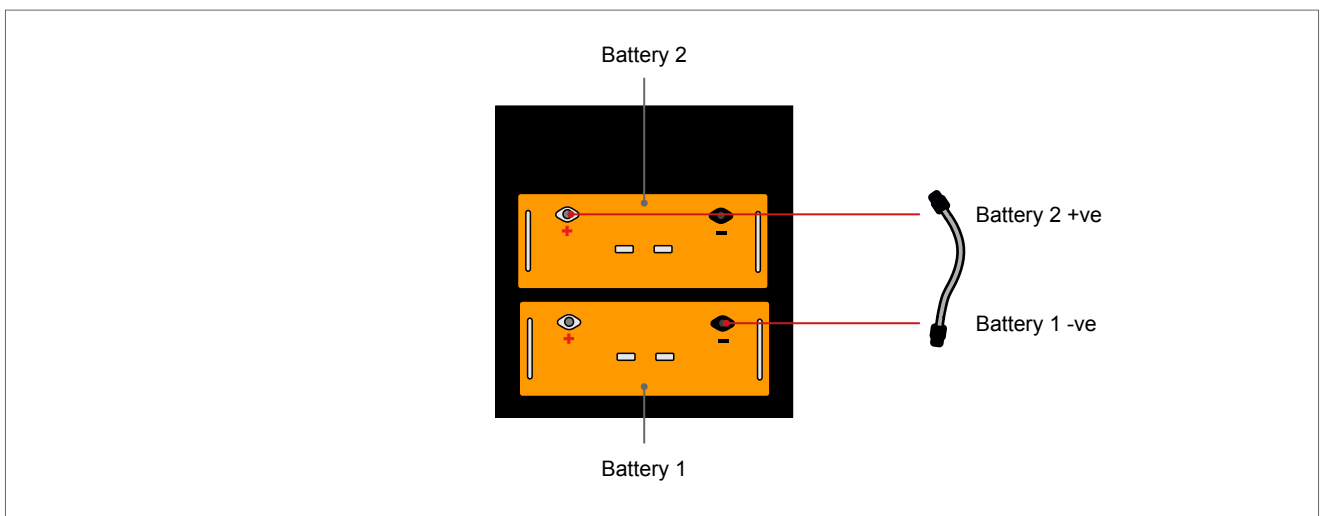

3. When facing the battery, connect one end of the black cable to the lefthand terminal of the top battery. In other words connect the end of the black cable labelled Batt2 +ve to the positive terminal of Battery 2.

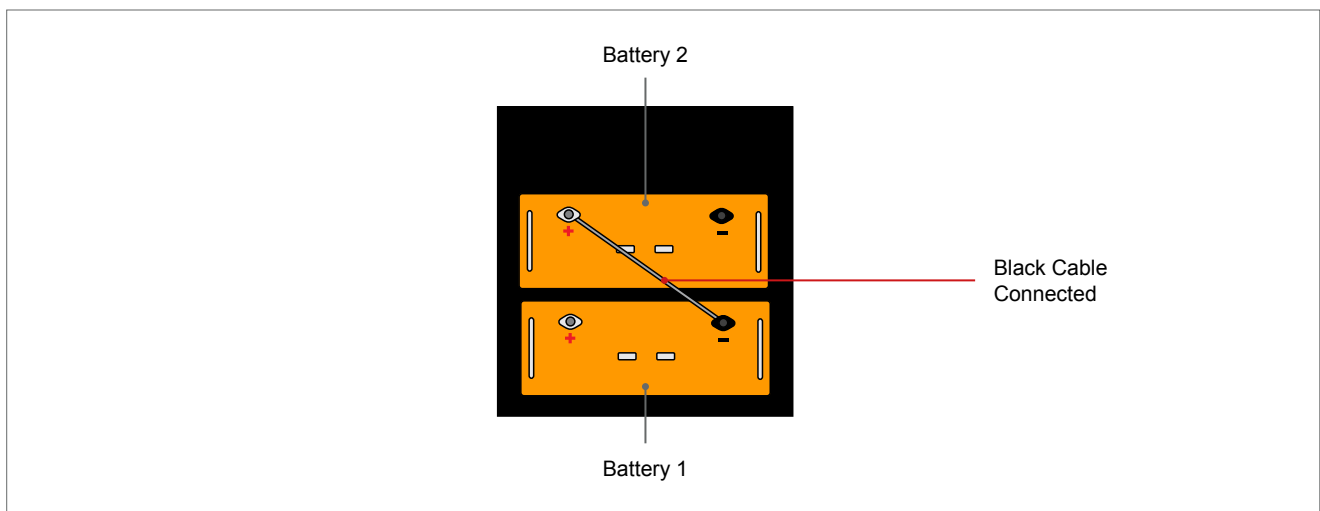

4. A common mistake is to connect the batteries .“backwards” . Do not connect +ve of Battery 1 (bottom battery) to -ve terminal of Battery 2 (top battery)

Step 4 Connect the main -ve out from the Batteries to the BMS

Watch the video of this step here:



1. Unpack BMS and place it in cabinet and secure.
2. Locate the Blue cable.
3. This cable is the main power out of the batteries. It carries the power of the batteries out of the batteries and into the BMS. The power then travels through the BMS to the other BMS terminal.
4. Connect the end labelled battery to the righthand terminal on the top battery, -ve terminal on Battery2.
5. Connect the end labelled BMS to the righthand terminal on the BMS.

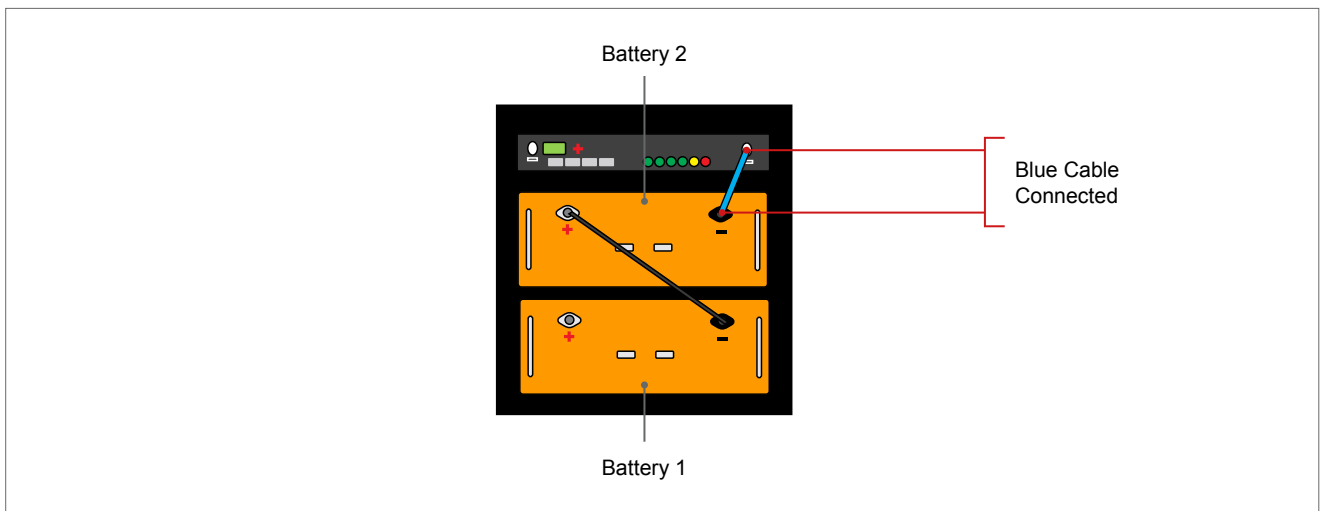

Step 5 Connect Monitoring Cables

Watch the video of this step here:



1. Locate the Black Monitoring and Management Interface cables, There are 4 black cables that connect the comms ports on the BMS to the corresponding ports on the Batteries.
2. Identify the communications ports on the BMS and the Batteries (labelled COM1 and COM2), These are used to monitor and optimize the battery functioning.
3. Each Black cable has both ends labelled. The label indicates which port the cable should be plugged into.

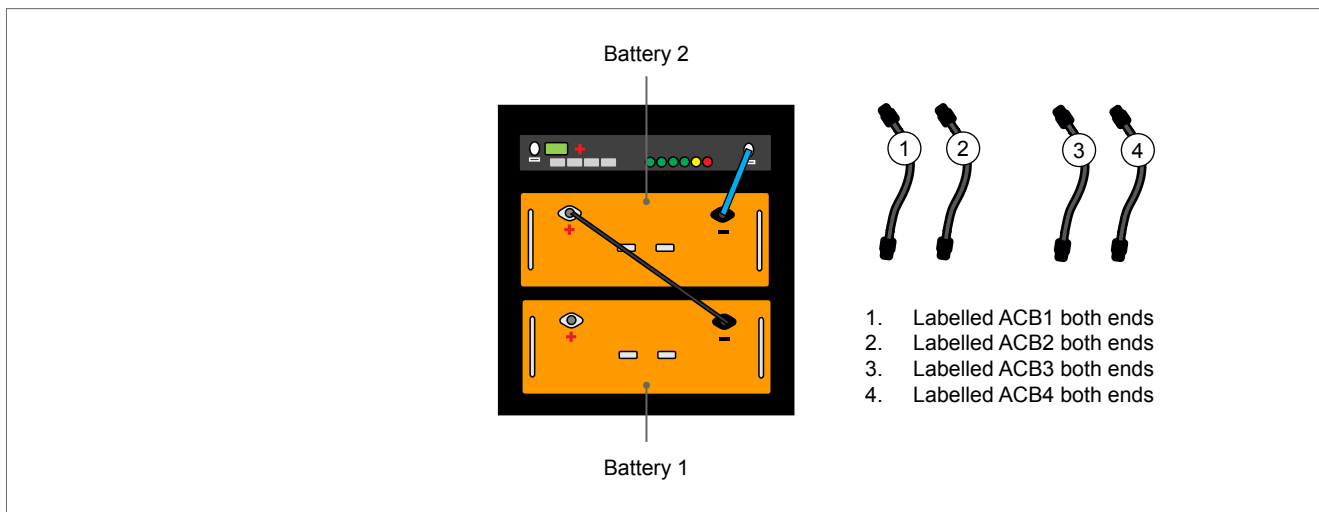

4. Find the correct Black Cable, each one is labelled so that a specific plug will match to a specific port.
5. Plug ACB1 into the leftmost port on the BMS and the port labelled COM1 on top Battery - Battery 2.
6. Plug ACB2 into the second port (2nd from the left) on the BMS and into COM2 on the top battery - Battery 2.
7. Plug ACB3 into the 3rd port from the left on the BMS and into COM1 on bottom battery – Battery 1.
8. Plug ACB4 into the rightmost port on the BMS and into the port labelled COM2 on bottom battery – Battery 1.

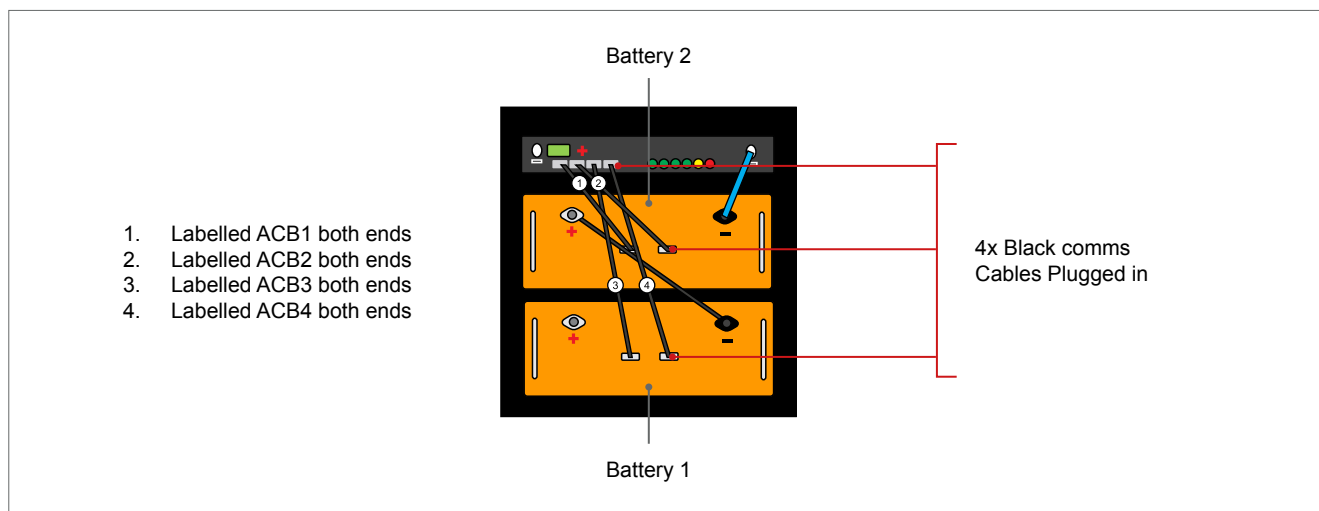

9. Each Black comms Cable has one end in the battery and one end in the BMS

Step 6 Main Power Cables out of cabinet from BMS and from Batteries

Watch the video of this step here:



1. This step connects the Main Power carrying cables from battery pack out to the rest of the system.
2. We will first connect the Main Power Out of the cabinet from BMS.
3. Connect Negative from BMS out of the cabinet.
 - a. Locate the BLUE cable.
 - b. Insulate the one end contact with electrical insulation tape.
 - c. This is the Main Power cable out of the BMS.
 - d. The Blue cable connects to the BMS and then goes out of the Battery cabinet to connect to the rest of the system. (In Revov recommended configuration it will connect to a fuse and circuit breaker and then to the Battery Busbar and eventually to the Inverter).
 - e. Feed the Blue cable through the appropriate cable path in the cabinet so the insulated end is outside the cabinet the uninsulated end is ready to be connected to the left terminal on the BMS.
 - f. Connect the un-insulated end of the BLUE cable labelled BMS to the left terminal on the BMS.
4. Connect the Positive from +ve terminal on Battery 1 out of cabinet, this is the Main Power Out of the cabinet from the Batteries.
 - a. Locate the BROWN cable.
 - b. Insulate the one end contact with electrical insulation tape.
 - c. This is the Main Power cable out of the Batteries.
 - d. The BROWN cable connects to the Batteries and then goes out of the
 - e. Battery cabinet to connect to the rest of the system. (In Revov recommended configuration it will connect to a fuse and circuit breaker and then to the Battery Busbar and eventually to the Inverter).
 - f. Feed the BROWN cable through the appropriate cable path in the cabinet so the insulated end is outside the cabinet the uninsulated end is ready to be connected to the left terminal on the bottom battery.
 - g. Connect the un-insulated end of the BROWN cable labelled Battery to the left (+ve) terminal on the bottom battery.

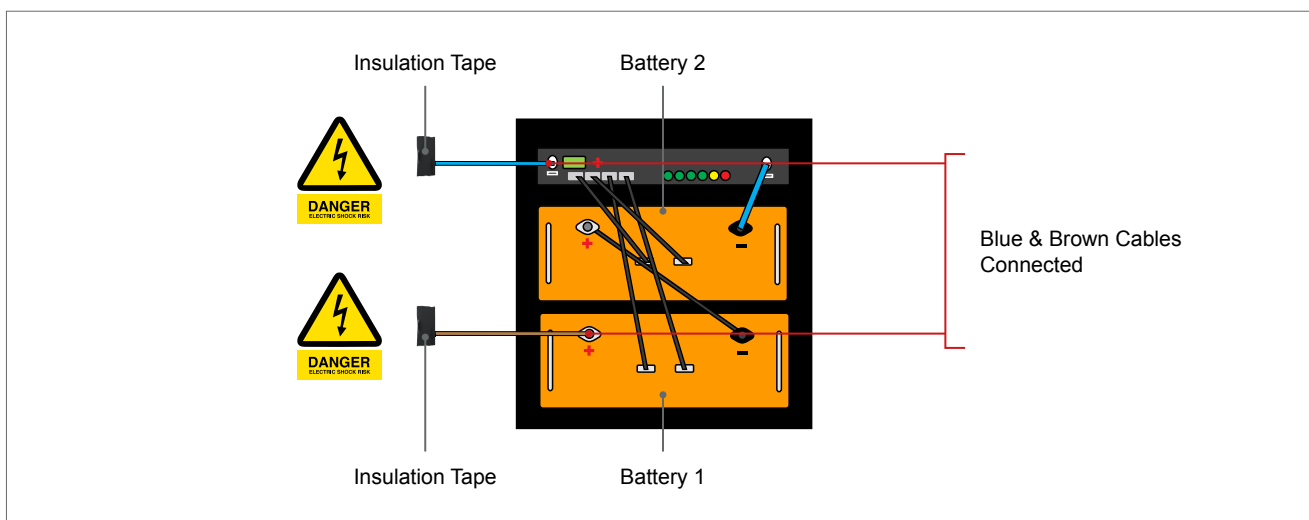

Step 7 Powering on the BMS itself

Watch the video of this step here:



1. Locate the slim BROWN cable.
2. This cable will connect the BMS to the battery in order to power the BMS itself.
3. Use your Flat screw drive to cable plug from the green connector from the BMS.

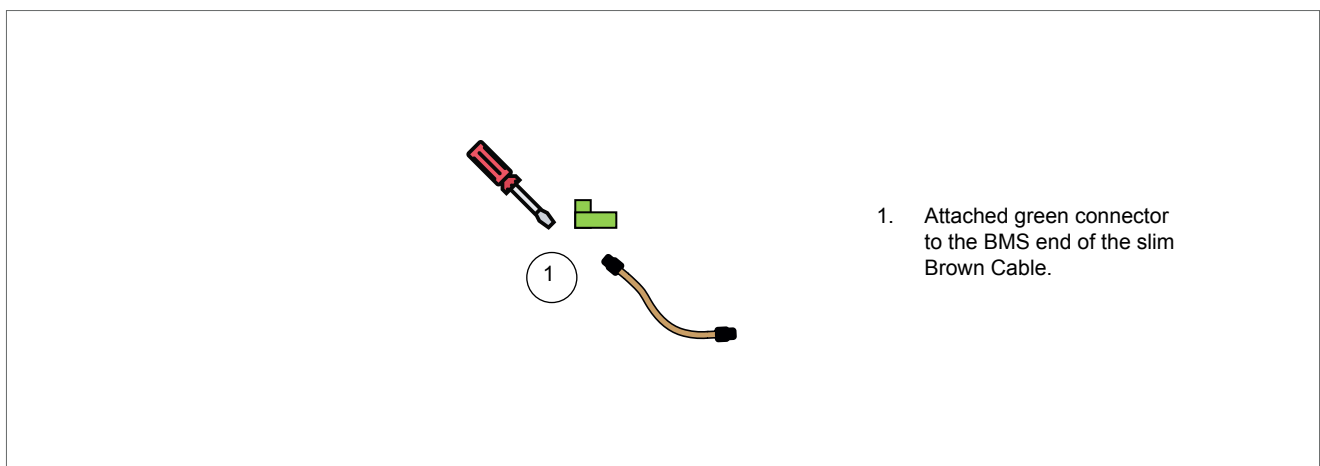

4. Insert the slim Brown Cable into the connector plug you have just loosened and tighten the screw to hold the cable firmly into this little plug.
5. Connect the battery end of the slim BROWN cable to the positive terminal on the top Battery (the +ve terminal on Battery 1).
6. Plug green plug into the green connector on the BMS.

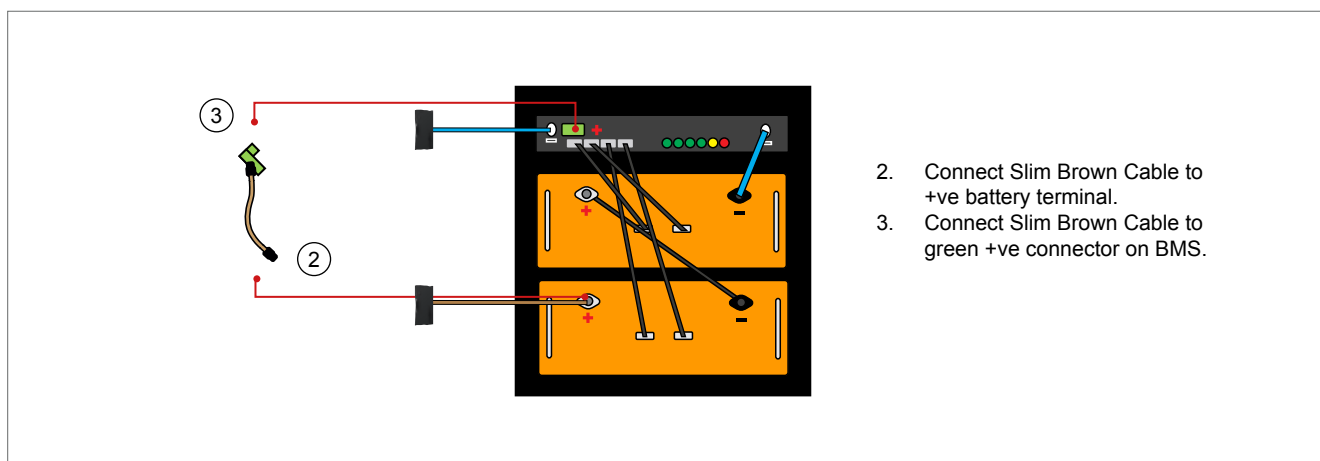

- The BMS will now switch on, the lights will all flash a few times and a beep will sound. Once the BMS has registered the batteries the lights will most likely just be green and show the state of charge of the battery pack, each green light that is on indicates 25% charge (eg. 1 green light indicates 25% charge, 2 indicates 50%).

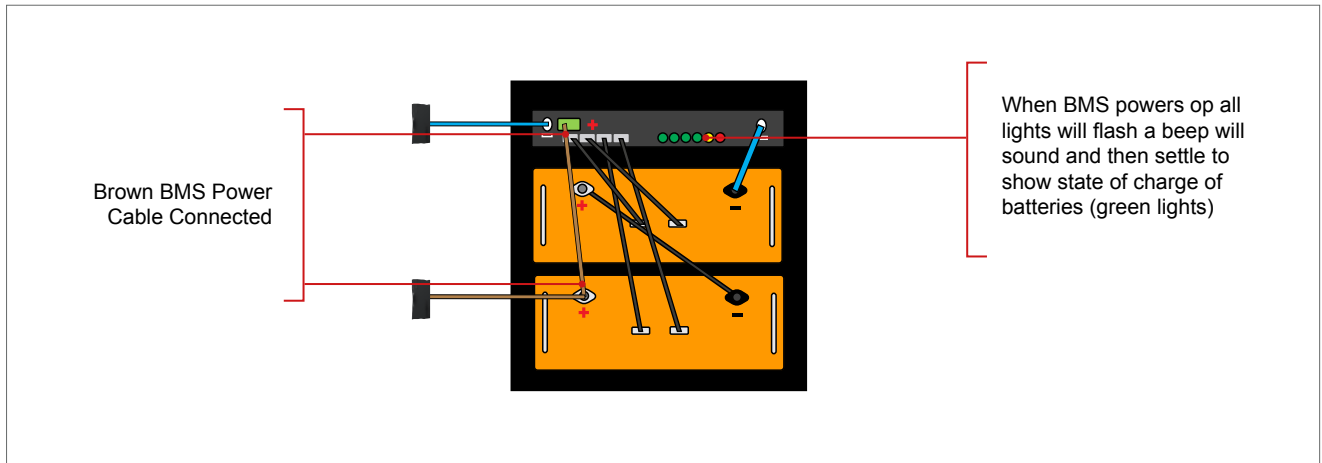

You have now successfully completed the assembly of your Revov battery pack.

The Revov battery pack is now ready to connect to the Balance of the System. A short overview of the balance of the system is provided below.

